

MM150

MM150

the thrill of finishing



# Automated Profile Finishing

## Twice as Efficient as Hand Spraying!

- ✓ Denibbing
- ✓ Spraying
- ✓ Wiping

- ✓ Affordable
- ✓ Mobile
- ✓ Easy to use



## Experience the Comfort of Automated Finishing

Give your profiles the finishing touch they deserve with the affordable, high-performing MM150. Positioned in the spraying zone of a functional spray booth, the booth's face air velocity offers sufficient protection from non-captured overspray for both booth operator and surrounding area. Its convenient Rollaway Casters make transport to and from your spraying zone an easy task.

Thanks to the Air Logic Controller, the MM150's spray guns are triggered on demand so they will never spray longer than needed. This timely gun triggering in combination with accurate and efficient gun positioning angles makes the MM150 up to 30% more efficient than conventional hand spraying.

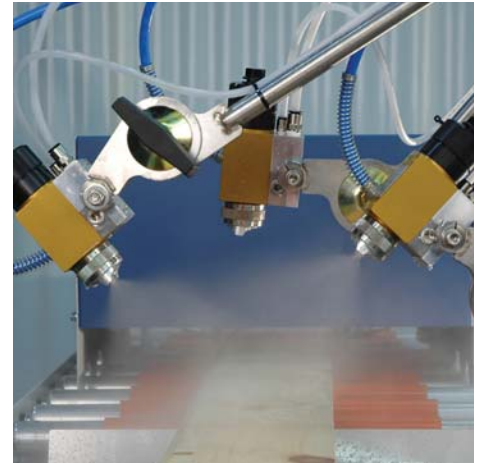

8" MM150 with denibbing brush

12" MM220 with denibbing and wiping brushes, spray enclosure, and exhaust unit

**Disclaimer:** Specifications may change without notice. As with all processes and chemicals, it is important that the potential health and safety hazards associated with the use of the MM150 are understood and that chemicals and equipment are handled safely in the workplace and with proper exhaust and ventilation. It is the responsibility of the users to read and understand "Material Safety Data Sheets", labels, equipment instructions, installation and maintenance procedures.

## Meet The MM150

Three Spraying Arms ready for your choice of spray gun system

Optional Brush Unit prepares substrates for perfect coating

Pump Mount and Coating Tray hold up to 5 gallon coating container and the spray system's pump

Air Logic Controller automatically triggers spray guns on and off

Overspray Tray collects overspray for reuse or recycling

Control Panel for adjustment of running speed and emergency stop

Casters provide mobility for easy storage when machine is not in use

Drive Motor powers the transportation rollers

Pneumatic Control Panel provides full control of spraying operations

Easy Feeder Fence and Pinch Roller keep substrates precisely on track

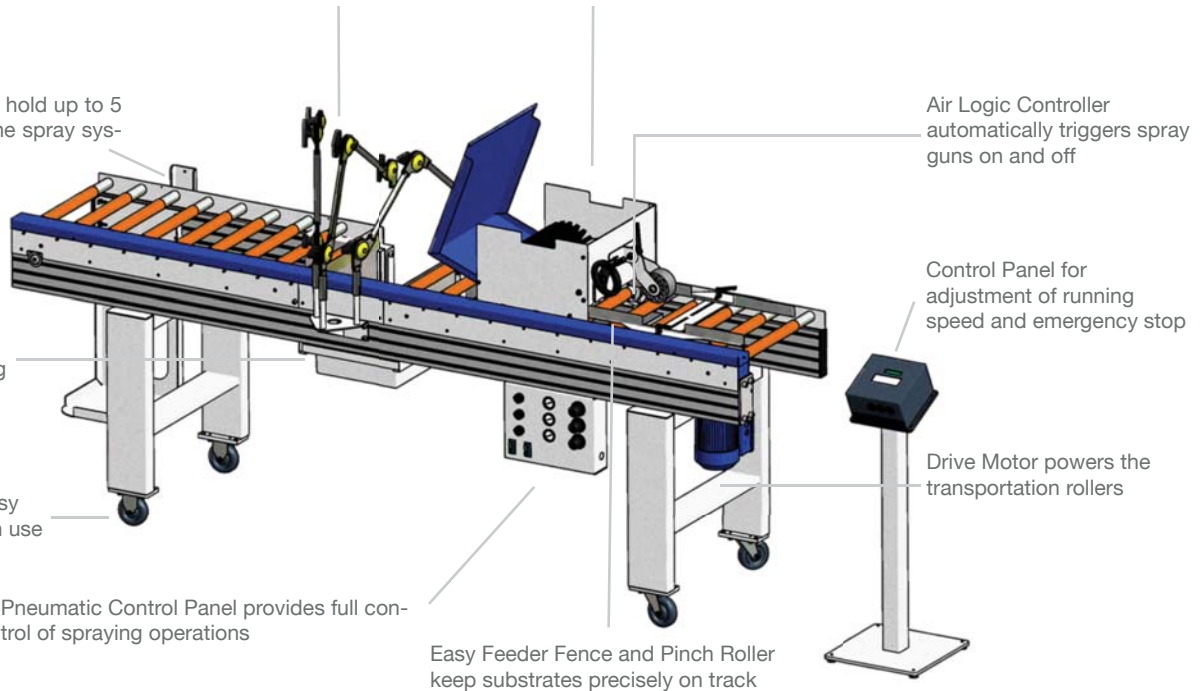

## Technical Information

Feed speed	From 30 to 150 fpm (9 to 45 m/min) Inverter controlled
Standard work-piece dimensions	Width up to 8 in. (200 mm) (optional up to 12 in. (300mm)) Height 0.5 to 3 in. (10-76 mm) Minimum Length 30 in. (800 mm)
Spray capability	Up to 3 automatic guns
Power requirement (with exhaust)	12A @ 110V / 1Ph / 60Hz 6A @ 480V / 3Ph / 60Hz
Overall dimensions	Width 30 in. (760 mm) (8 in. model) Length 98 in. (2500 mm) Height 59 in. (1500 mm)



## Accessories



### Brush Unit

The MM150's Brush Unit gently brushes off small fibers from the wood surface without generating new ones and smoothes the surface for improved topcoat adherence. All this and the easy replacement of the abrasive brush strips make this denibber a must have for your MM150.



### Roll-On Exhaust Unit

No stationary spray booth is needed with the MM150's Roll-On Exhaust Unit. Aided by a fan, the Roll-On Exhaust Unit filters overspray not captured in the overspray tray making your shop a safe and clean working environment.



### Spray System

The MM150 is ready to be equipped with three spray guns and a pump of your choice. A powerful high-pressure or membrane pump transports coating to the spray guns. Quick-Adjust Arms provide total control over the spraying angle while the guns atomize the fluids for consistent coating transfer and precise spraying.



### Special Sizes & Configuration

Be completely flexible with the MM150's various special size conveyors. Upon request your machine can be equipped with conveyors that handle multiple sanding units, extra large or extra small substrates.



### Stain Wiping Unit

Create a more vivid finishing with the MM150's Wiping Unit. Its soft brush wipes away excess stain to bring out the wood's natural grain. The Wiping Unit assures to be an accessory you will not want to miss, making your MM150 take care of the complete finishing process.

### Tailor-Made for You

To meet your specific finishing needs, we have developed a variety of accessories for the MM150. Each machine is custom-made to match your personal preferences.

**Build your own MM150 at  
[www.MM150.info](http://www.MM150.info)**